

35 K17



EXCLUSIVE EDITION

UPGRADE SET
FOR DRAGON
1/35 MODEL

GERMAN TANK DESTROYER JAGDPANTHER

(Sd.Kfz. 173) - Ausf. G1

Early version

Niemiecki niszczyciel czołgów "Jagdpantner G1"- wczesna wersja

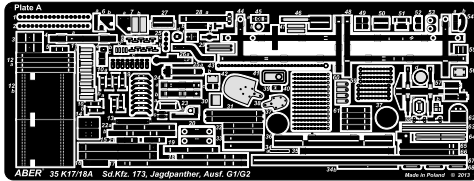
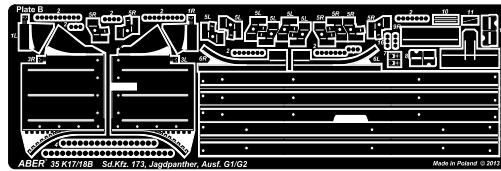
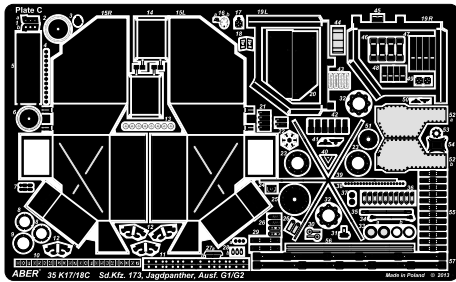
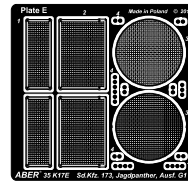
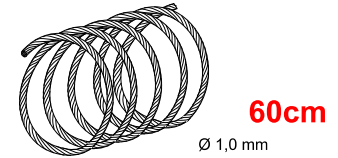
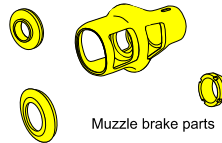
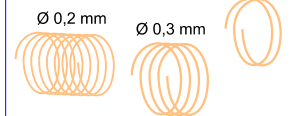
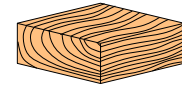
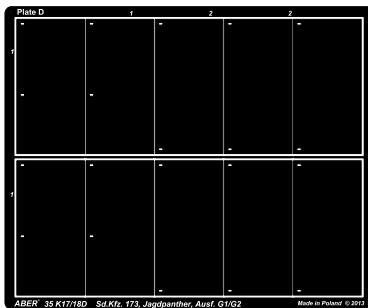
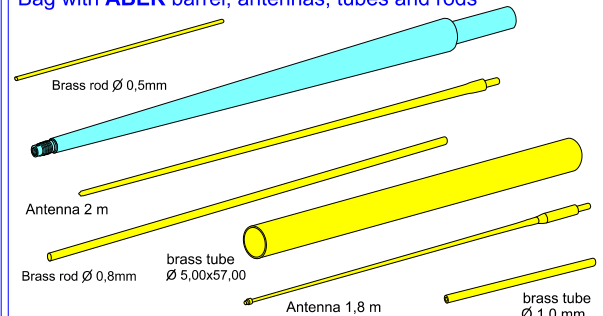
A**B****F****C****E****Bag with cable****Turned parts****Bag with wires****Bag with wood chock****D****Bag with ABER barrel, antennas, tubes and rods**

MOST IMPORTANT BIBLIGRAPHY:

- 1) Achtung Panzer No.4 - PANTHER, Jagdpanther & Brummbär by Mitsuru Bitoh - Dai Nippon Kaiga Co.,Ltd. ©1994
- 2) AFV Modeling Guide Vol.4 -Schwere Jagdpanzer - Geibusha Publishing ©2010
- 3) GROUND POWER No.007, 008, 189 - Delta Publishing Co.,Ltd. ©1995, ©2010
- 4) Militärfahrzeuge Band 9; Der Panzer-Kampfwagen Panther und Seine Abarten - Walter J. Spielberger - Motorbuch ©1994
- 5) Panzer Tracts No.9-3 -"Jagdpanther" Thomas L. Jentz & Hilary Louis Doyle
- 6) New Vanguard 22: PANTHER VARIANTS 1942-1945 - Osprey Military ©1997

Thank you for purchase our set **35 K17**.

Read carefully this instruction.

We advise that better method to join metal to metal parts is soldering.

Cement metal parts to plastic with good cyanoacryl or epoxy glue.

WARNING

Any unauthorized copying, producing and reproducing of ABER company products, or any part thereof, is strictly prohibited and any such action establishes liability for a civil action and may give rise to criminal prosecution.

OSTRZEŻENIE

Jakiegokolwiek kopiowanie, produkowanie i reprodukcja wyrobów firmy ABER bez zezwolenia, w całości lub części jest surowo zabronione. Powyższe działania powodują powstanie odpowiedzialności cywilnej oraz mogą spowodować wszczęcie postępowania karnego.

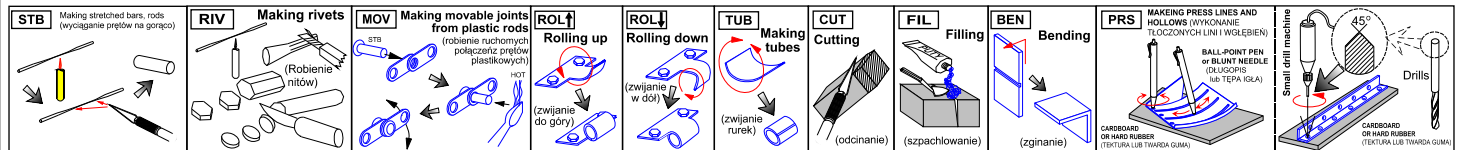

TOOLS RECOMMENDED

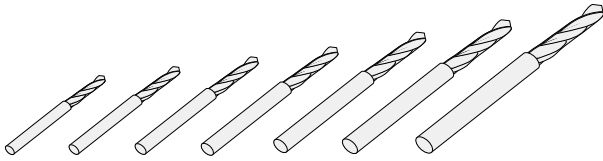

Drills from Ø 0,4 to 1,5 mm

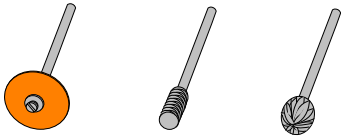

Assortment of cutting wheels and mills

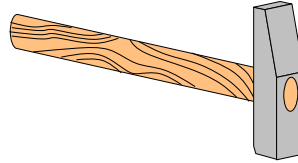

Light weight hammer

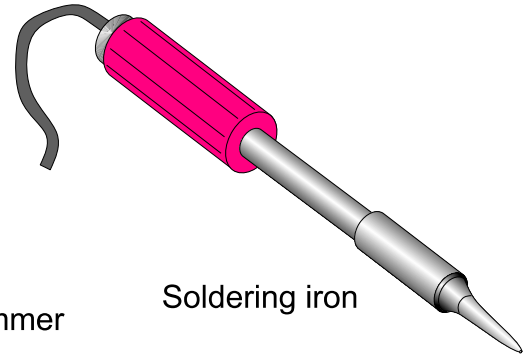

Soldering iron

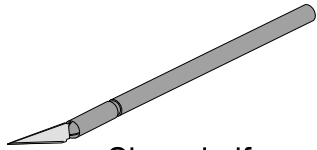

Sharp knife

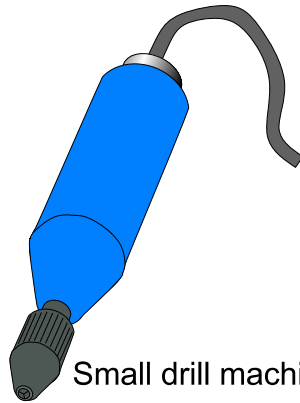

Small drill machine

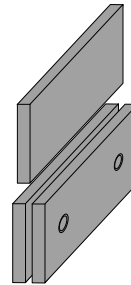

Bending tool
PG01 or PG02

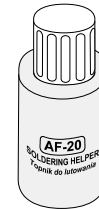

Soldering flux



Solder

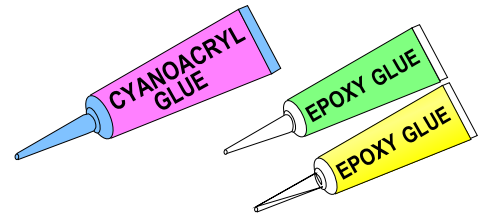

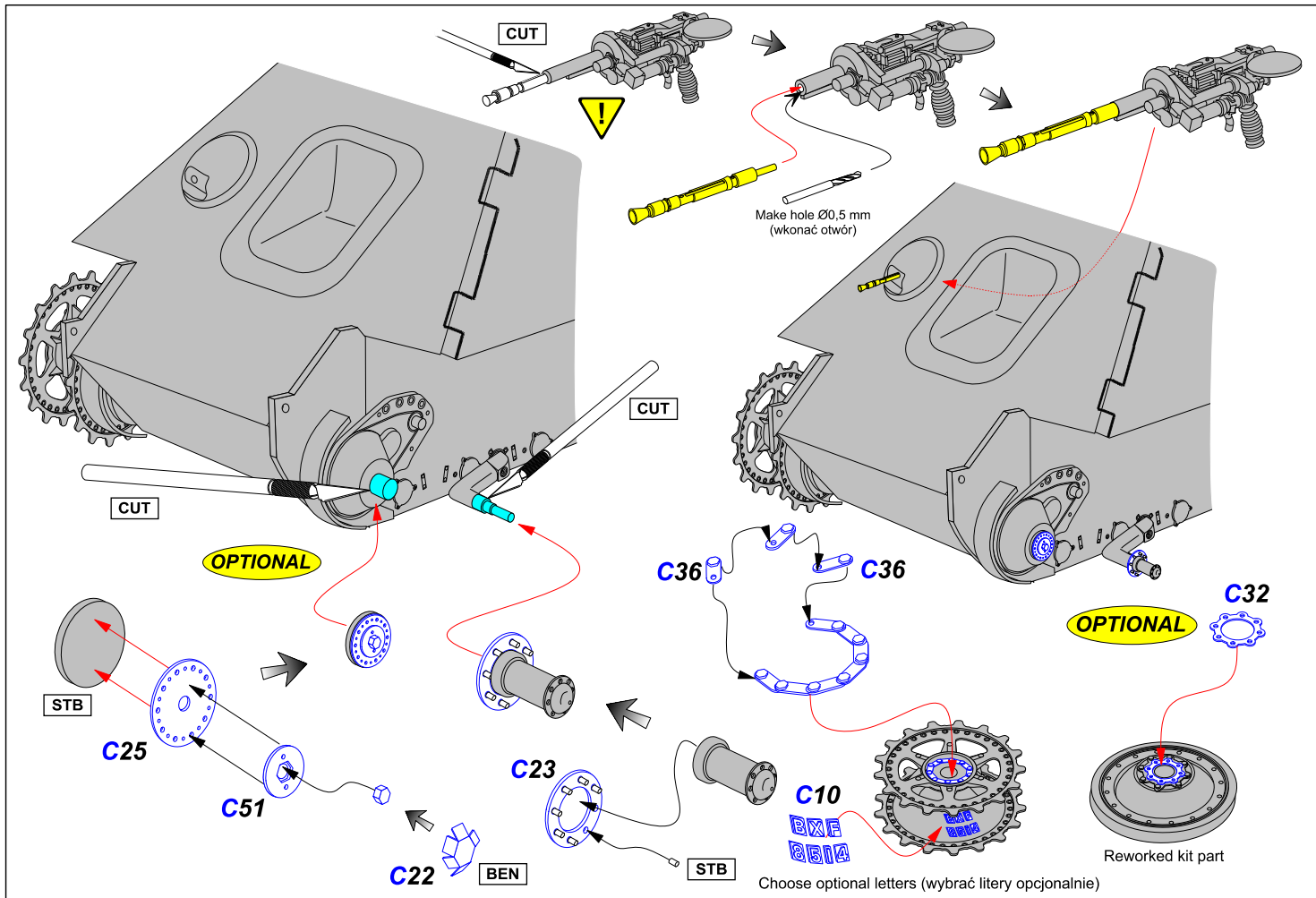

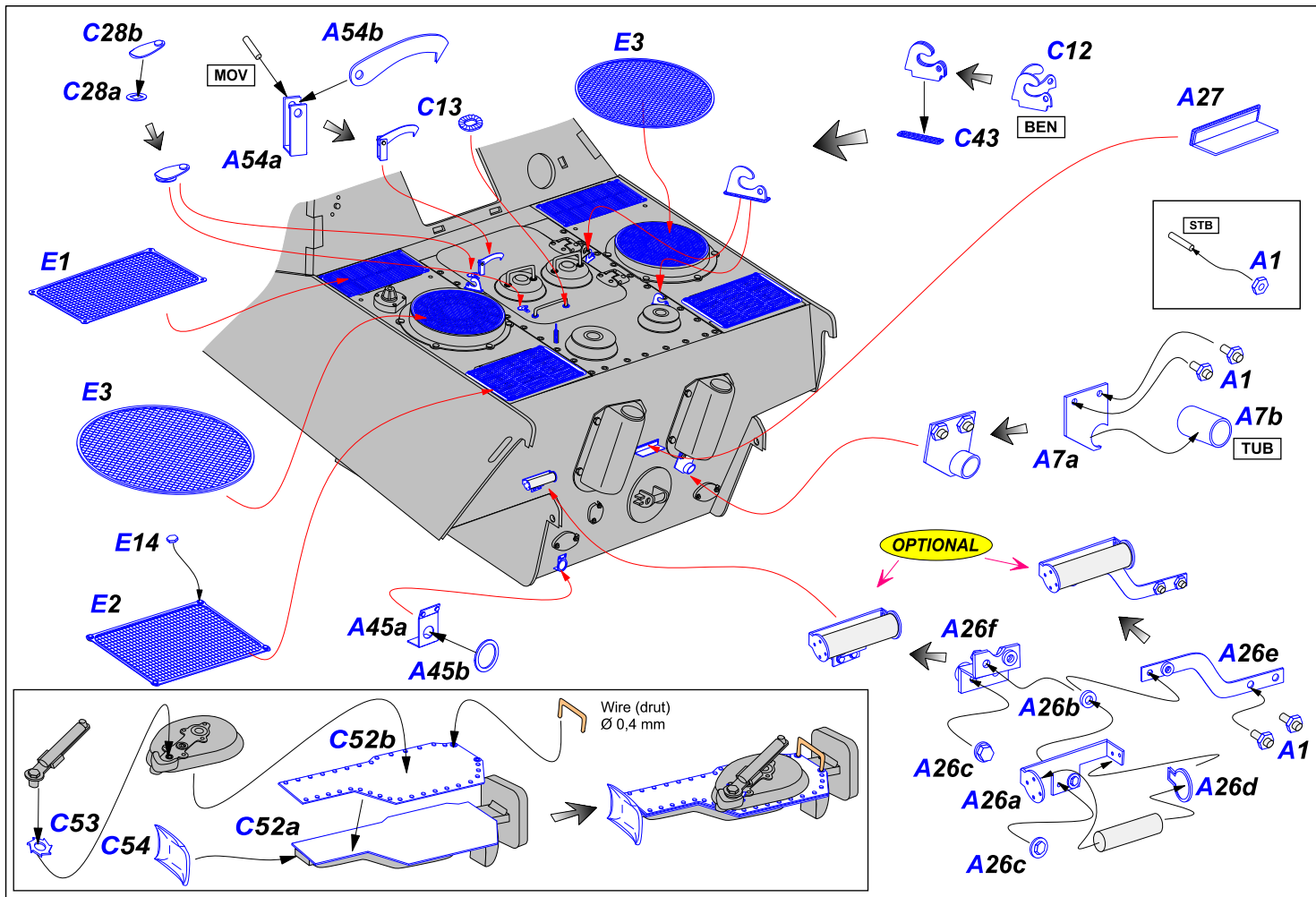

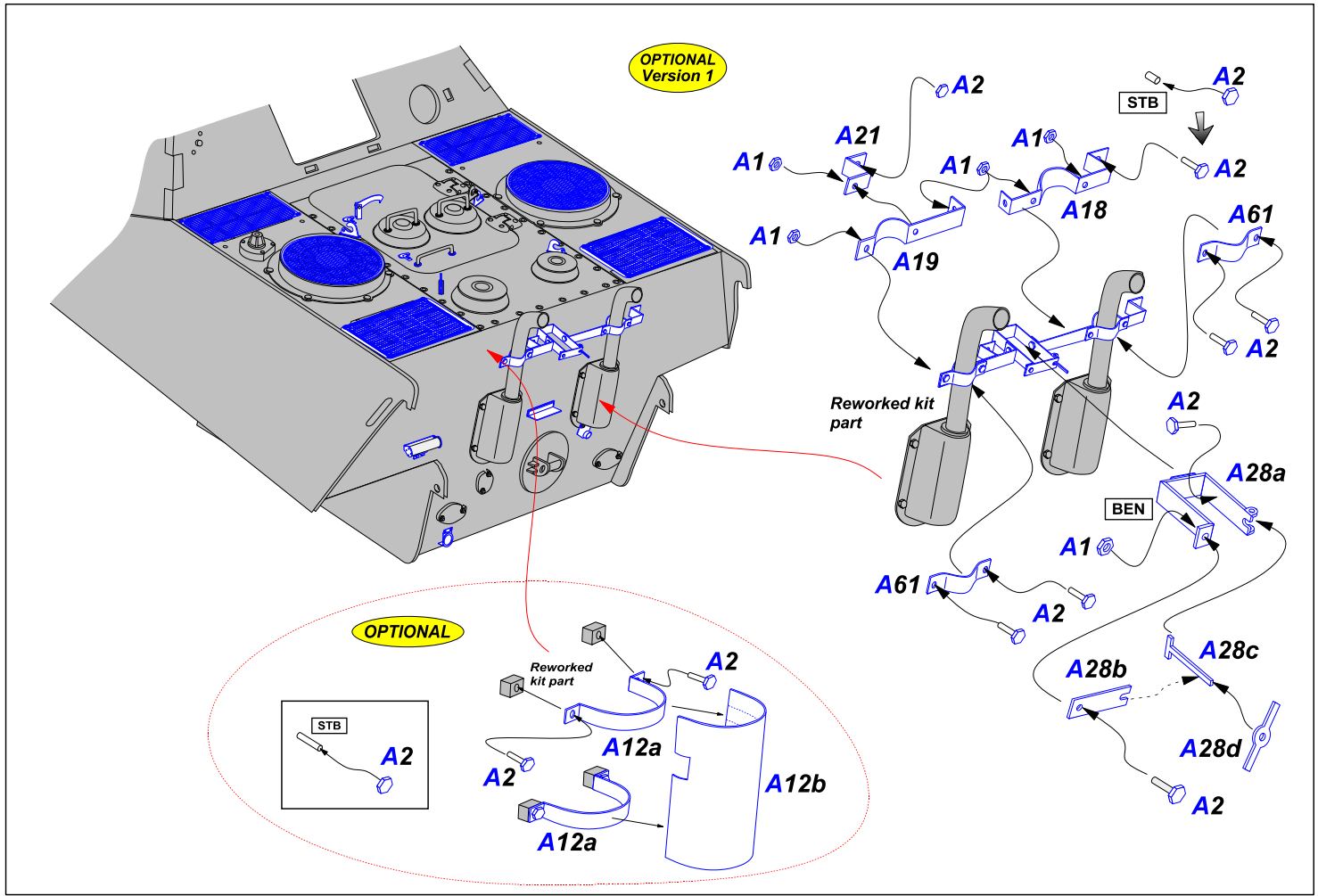

OPTIONAL
Version 2

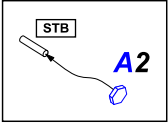
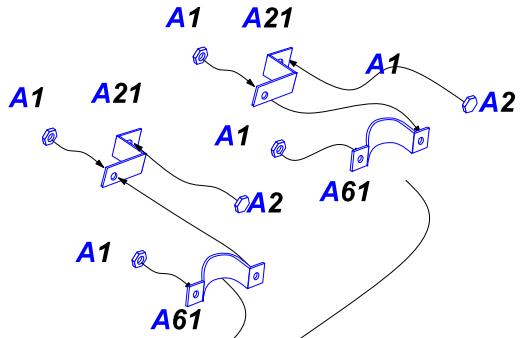
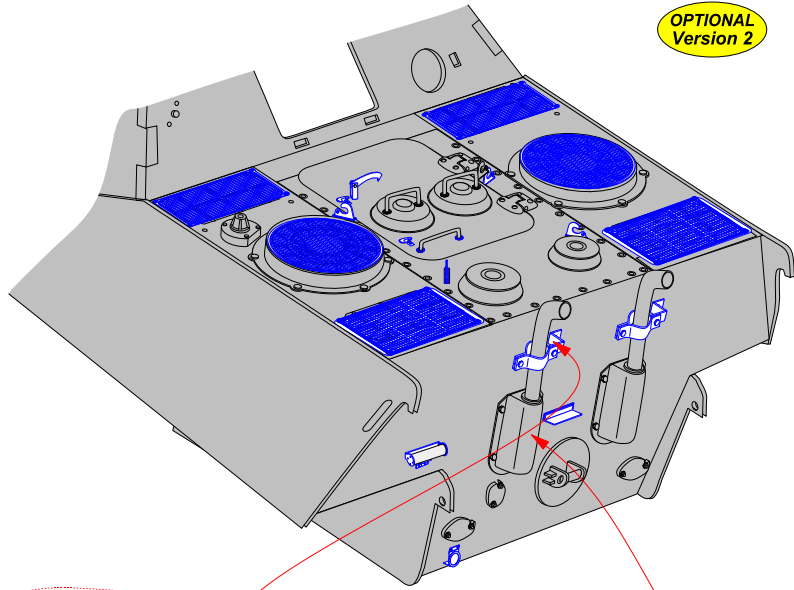

OPTIONAL

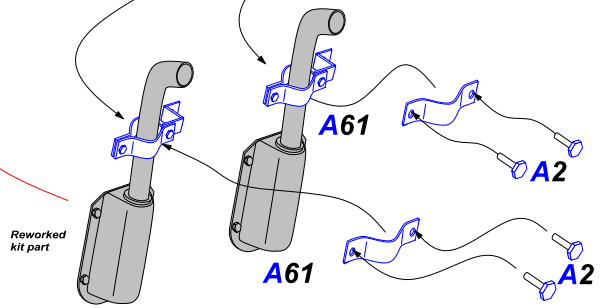
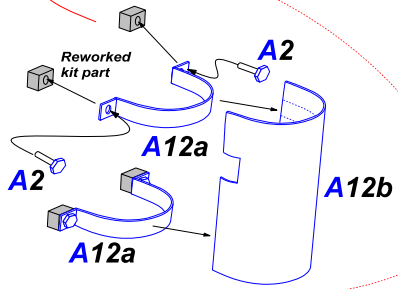

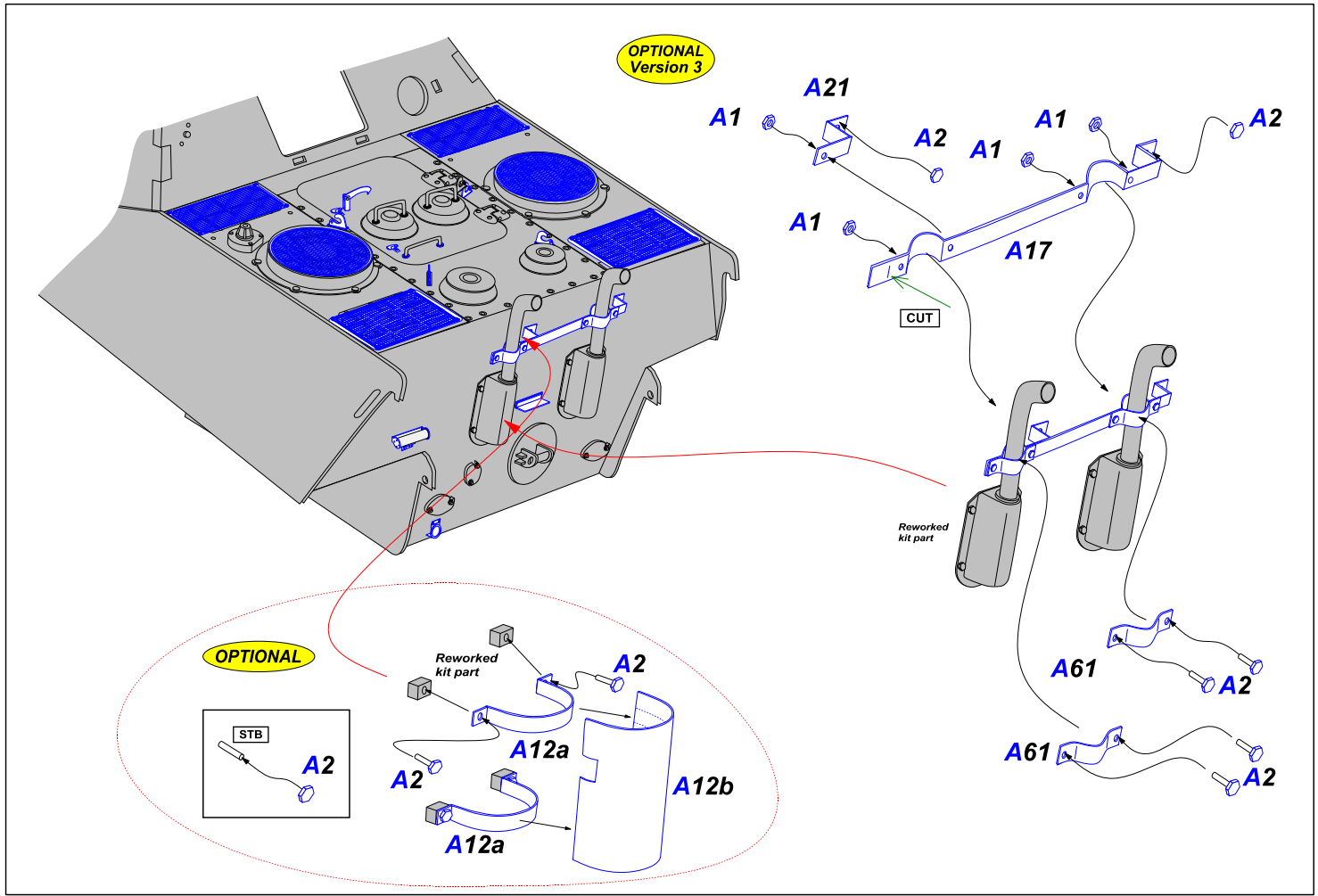

OPTIONAL
Version 4

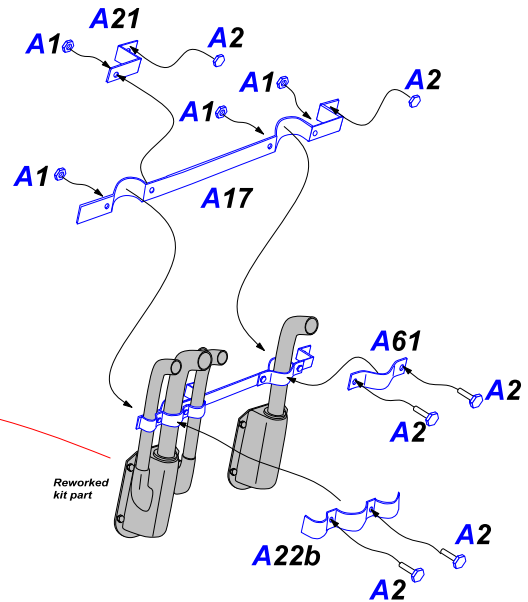
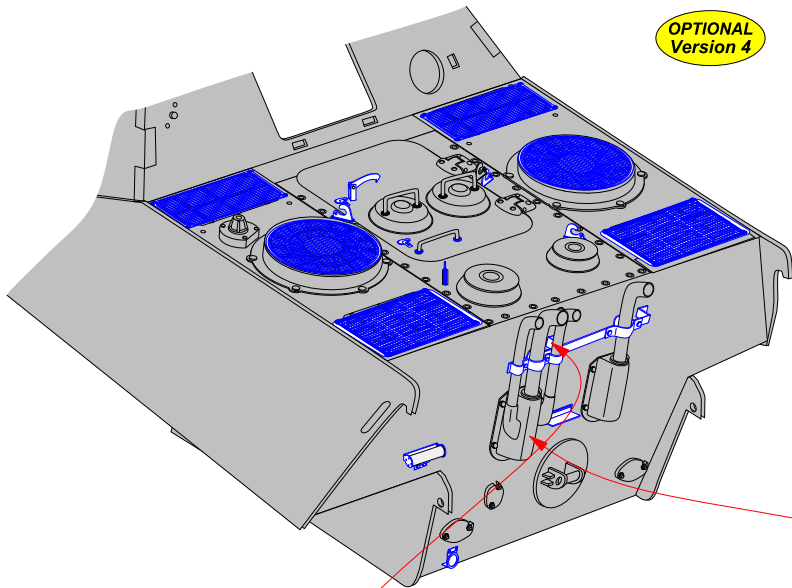

OPTIONAL

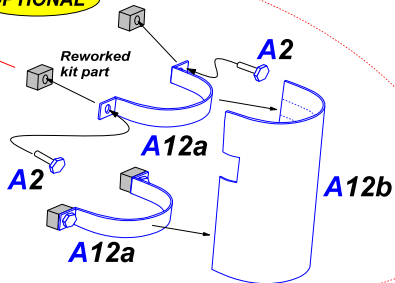
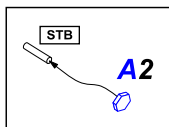

OPTIONAL
Version 5

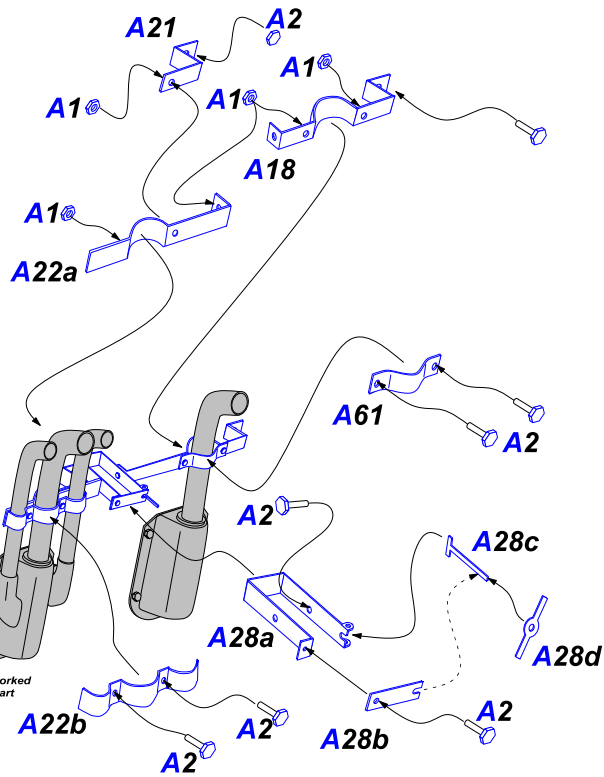
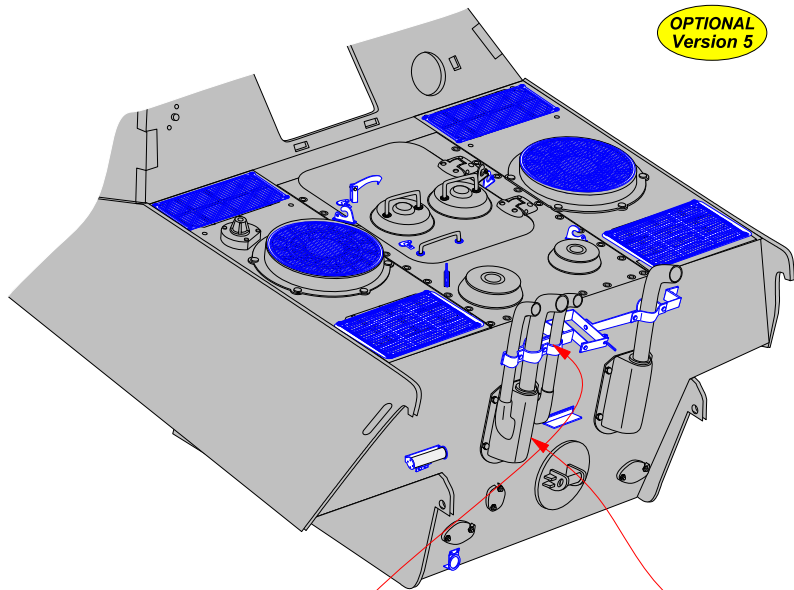

OPTIONAL

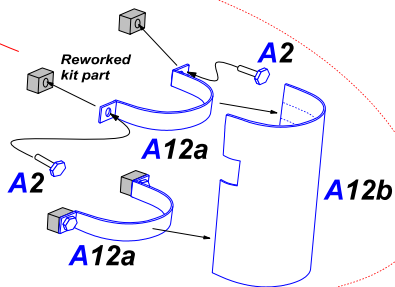
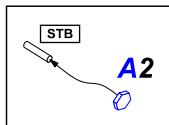

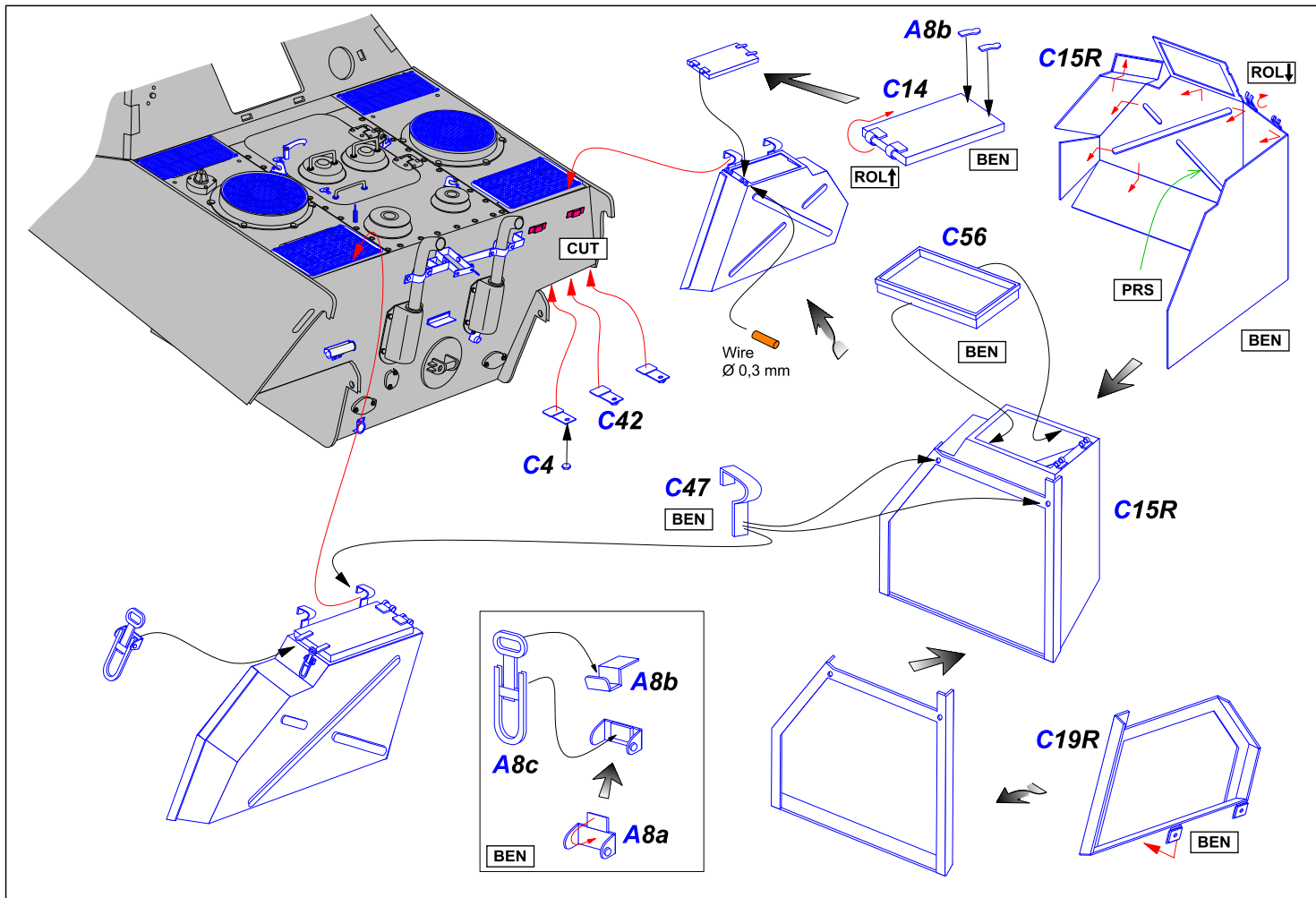

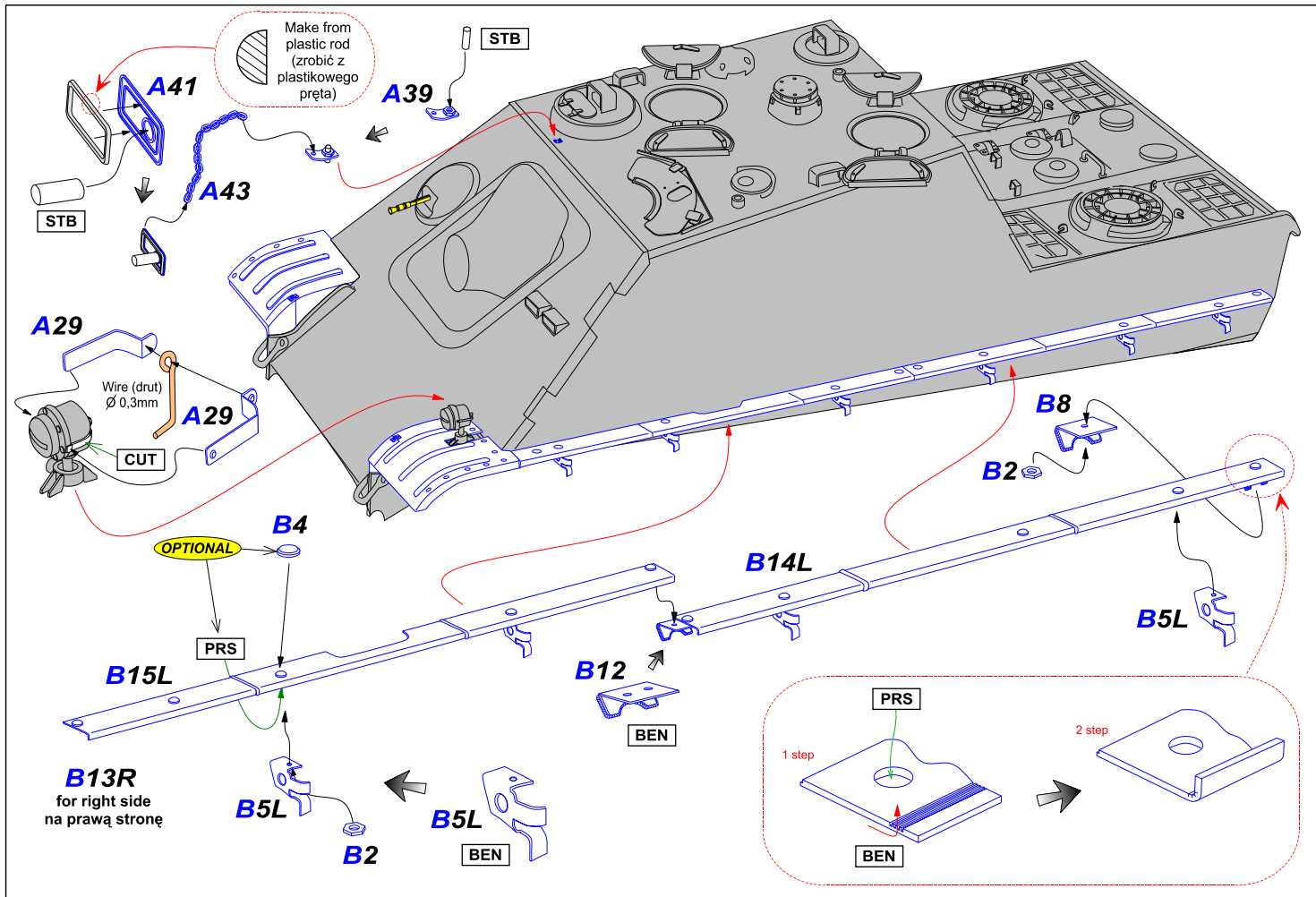

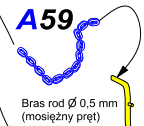
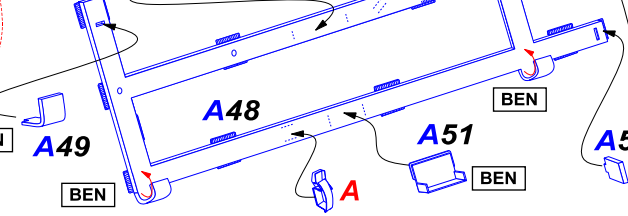
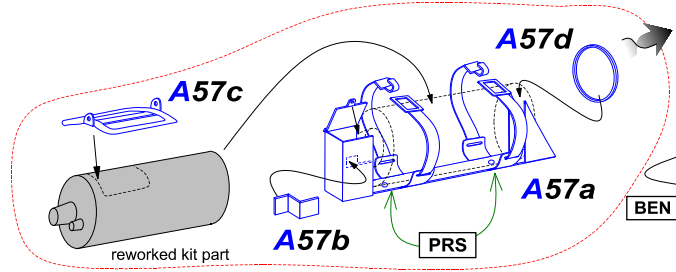
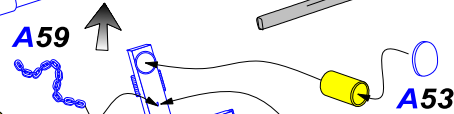
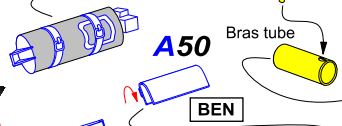
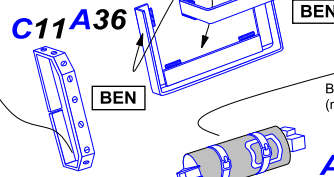
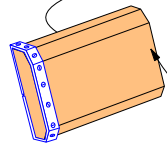
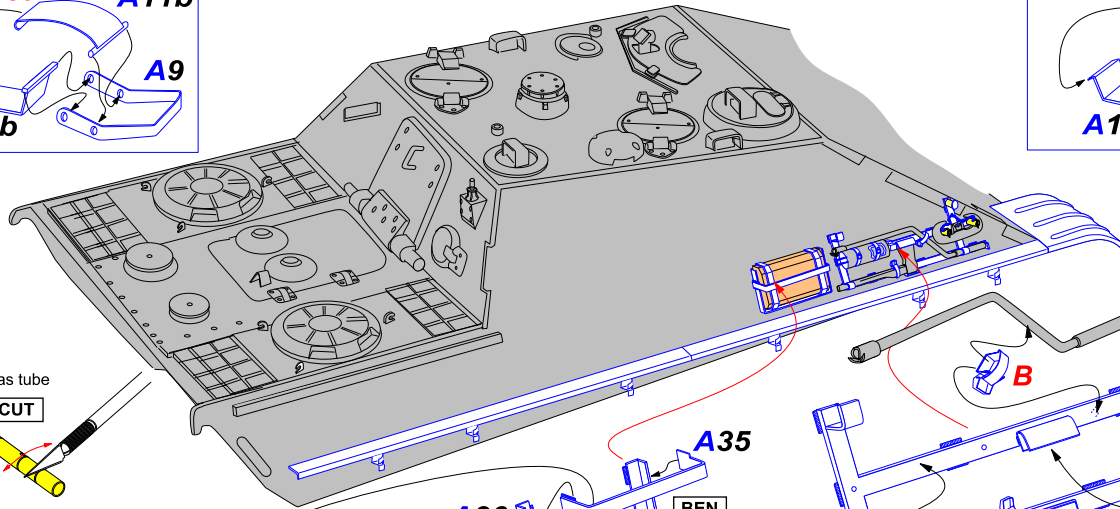
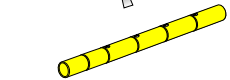
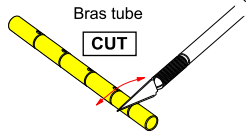
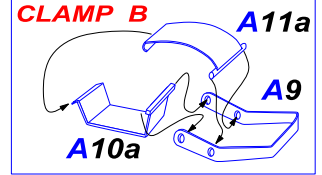
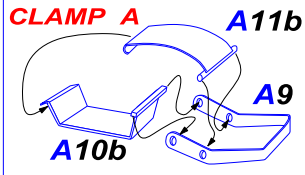

Bras rod \varnothing 0.5 mm (mosiężny pręt)

Bras tube

